

INSTRUCTIONS FOR INSTALLING THE 151999, 152950 OR
162361 RECTIFIER AND CABLE ASSEMBLY ON THE
MODEL 28 ELECTRICAL SERVICE UNIT; CONVERTING
THE 151999 ASSEMBLY TO A 152950 ASSEMBLY USING
THE 153477 CABLE ASSEMBLY; INSTALLING 160422
MODIFICATION KIT TO EQUIP MODEL 28 AUTOMATIC
SEND-RECEIVE (ASR) CABINET WITH RECTIFIER

Information in the Chart below pertains to Bell System only

UNIT	TELETYPE CODE	BELL SYSTEM CODE
Electrical Service Unit	LESU5 LESU7/134 LESU7/184	28A 28E 28B

1. GENERAL

a. 151999 or 152950 RECTIFIER AND CABLE ASSEMBLY.

(1) The 151999 (for LESU1, LESU2, LESU5, LESU6) or 152950 (for LESU7), rectifier and cable assembly provides a source of direct current to operate the local selector magnet and the bias winding of the local line relay on the Model 28 Printer when no direct current is available for the installation. The 152950 assembly also supplies current for a local line test key circuit and supplies local loop current when no direct current is available for the installation. For maximum rated output, see Paragraph 1. a. (4).

(2) The rectifier assembly is wired for full wave rectification and consists of an insulated input transformer, two silicon diodes, a filter capacitor, a metal base on which all parts are secured, and wiring cables. The assembly is mounted on the electrical service unit.

(3) The rectifier assembly is 4-3/4" long, 2-7/8" deep, and 5-7/8" high.

(4) The rectifier ratings are:

Input Voltage: 105 to 125 volts, 60 cycles single phase ac.

Output Voltage; with 115 volts ac input:

115 (+ 4) volts dc at 0.12 ampere load.

Note over 135 volts dc at no load

Not less than 108 volts dc at 0.150 ampere load

Continuous output current at 167°F. (75°C.) ambient temperature: 0.150 amperes.

ac component in dc output: Not more than 2% RMS at 0.12 ampere.

NOTE

When installing the 151999 rectifier and cable assembly on electrical service unit LESU1, it is essential that the service unit be equipped with a 152126 auxiliary terminal block as shown in Figure 1. The 152126 auxiliary terminal block kit must be ordered separately. Instructions for installing the terminal block kit on the LESU1 may be found in Teletype Specification 5693S which is furnished with the kit.

b. 153477 CABLE ASSEMBLY - This assembly is for converting the 151999 rectifier and cable assembly to a 152950 assembly.

c. 162361 RECTIFIER AND CABLE ASSEMBLY

(1) The 162361 rectifier and cable assembly (for LESU7 and up) provides up to 0.300 ampere of direct current from an alternating current source for normal operation and up to 0.500 ampere of direct current with reduced regulation. Because of the load-voltage characteristics of this type of rectifier (high output voltage at minimum loads) it is intended that this unit be employed in applications where the current requirements are greater than those of the 152950 rectifier and cable assembly. For maximum rated output of the 162361 assembly, see Paragraph 1. c. (4).

(2) This rectifier assembly is wired for full wave rectification and consists of an insulated input transformer, two silicon diodes, a filter capacitor, fuse holder and fuse, a cable and a base on which all parts are secured. The assembly is similar in appearance to, and occupies the same position on the electrical service unit, as the 152950 assembly.

(3) The rectifier assembly is 4-51/64" long, 2-7/8" deep and 6-5/16" high.

* (4) The rectifier ratings are:

(a) Input Voltage: 105 to 125 volts; 60 cycle single phase ac.

Output Voltage: with 115 volts ac input.

115 (+ 4) volts dc at 0.300 ampere load.

Not less than 108 volts dc at 0.500 ampere load.

Not over 135 volts dc at no load.

Continuous output current:

0.500 ampere up to 167°F. (75°C.) maximum ambient temperature.

ac component in dc output:

Not more than 2% RMS at 0.300 ampere.

d. 160422 MODIFICATION KIT

(1) The 160422 modification kit is for installation in Model 28 Automatic Send-Receive (ASR) Cabinets and provides a 0.500 ampere rectifier to supply current to the transmitter distributor clutch magnet coils.

(2) A 162361 rectifier assembly has been equipped with a mounting bracket and new cable and is included in the kit as Part No. 160441. For detailed information pertaining to the 162361 rectifier assembly, refer to Paragraph 1. c.

(3) The 160422 modification kit consists of:

2	55219	Screw	1	160441	Rectifier Assembly
2	115594	Nut, Speed	1	3495WD	Wiring Diagram

e. Specification 5664S covers instructions for the installation of a line relay mounting assembly on electrical service units.

f. For part numbers referred to and for parts ordering information, refer to Teletype Parts Bulletin 1149; Model 28 Page Printer Set (KSR) or 1169B; Model 28 Automatic Send-Receive Set (ASR).

2. INSTALLATION

a. 151999 ASSEMBLY

(1) Remove and discard the 151441 blank plate that is mounted on the electrical service unit next to the cover plate that contains the fuse sockets.

(2) Mount the 151999 rectifier assembly in place of the 151441 blank plate with the transformer toward the front. Tighten the mounting screws so that the 151427 clamp plates secure the assembly in position.

(3) Route and connect the 151825 cable as shown in Figure 1, 2 or 3.

b. 153477 CABLE ASSEMBLY (for converting the 151999 to the 152950 assembly).

(1) Unsolder and remove the 151825 cable assembly.

(2) Route and connect the 153477 cable as shown in Figure 5. Solder the red lead to the plus terminal on the capacitor and the associated black lead to the minus terminal. Solder the white lead to terminal 1 on the transformer and the associated black lead to terminal 2.

(3) To distinguish the converted assembly from a 151999 assembly, writer "152950 assembly" on the side of the unit. Use black paint, marking crayon, or other form of durable marking.

(4) Follow procedure in Paragraph 2. c.

c. 152950 ASSEMBLY (for use on electrical service unit LESU7).

(1) Remove and discard the center blank plate that is mounted on the electrical service unit.

(2) Mount the 152950 rectifier assembly in place of the center blank plate with the transformer toward the front. Tighten the mounting screws so that the 151427 clamp plates secure the assembly in position.

(3) Route and connect the 153477 cable as shown in Figure 5.

d. 162361 ASSEMBLY (for use on electrical service unit LESU7 and up).

(1) Remove and discard the 151441 blank plate that is mounted on the electrical service unit.

(2) Mount the 162361 rectifier assembly in place of the center blank plate with the transformer toward the rear. Tighten the mounting screws so that the 151427 clamp plates secure the assembly in position.

(3) Route and connect the 153477 cable as shown in Figure 6.

e. 160422 MODIFICATION KIT

(1) Slip the two 115594 speed nuts on the horizontal mounting strips in the lower rear portion of the cabinet. These nuts should be added to two adjacent holes in any convenient location.

(2) Partially screw the two 55219 screws into the speed nuts.

(3) Route the cable through the left rear cabinet shelf hole and to the appropriate terminals, as shown on Wiring Diagram 3495WD furnished with the kit.

(4) Hang the 160441 rectifier assembly on the two 55219 screws and tighten.

3. WIRING

a. 151999 ASSEMBLY (Figures 1, 2 or 3) for electrical service unit LESU5.

NOTE

For circuit wiring, see Figure 4; Figures 1, 2, or 3 show where loose cable connections are to be made.

(1) For standard rectifier operation, wire in accordance with Figure 1, 2, or 3. Disregard the orange and blue leads which are dead ended and taped in the 151825 cable.

(2) For continuous rectifier operation, wire as follows:

(a) For electrical service unit LESU1, connect the black and red leads to the auxiliary terminal block as shown in Figure 1.

(b) For electrical service unit LESU2, connect the black and red leads on the selector magnet terminal block as shown in Figure 2.

(c) For electrical service units LESU1 and LESU2, tape the white lead and the green lead. Remove the tape covering from the orange and blue leads. Solder the blue lead from the rectifier assembly to the side terminal of the fuse socket which is nearer the convenience outlet. Solder the orange lead to the side terminal of the other fuse socket.

(d) For electrical service units LESU1, LESU2, LESU3, LESU4, and LESU5 on the power terminal block, attach white lead to terminal 1, and attach green lead to terminal 9. Connect the black and red leads on the selector magnet terminal block as shown in Figure 3.

b. 152950 ASSEMBLY (for electrical service unit LESU7) or 162361 ASSEMBLY (for electrical service unit LESU7 and up).

NOTES

151999 assembly - for circuit wiring see Figure 4A. Figure 1, 2, and 3 shows where loose cable connections are made.

152950 assembly - for circuit wiring, see Figure 4C. Figure 5 shows where loose cable connections are to be made.

162361 assembly - for circuit wiring, see Figure 4B. Figure 6 shows where loose cable connections are to be made.

Should the fuse fail a 0.8 ampere fuse should be used as a replacement.

(1) Connect the black rectifier lead:

(a) For standard operation (rectifier controlled by power switch) to terminal 2 of terminal block E.

(b) For continuous rectifier operation, to terminal 1 of terminal block E.

(c) For rectifier operation controlled by the electrical motor control, to terminal 3 of terminal block E.

c. 160422 MODIFICATION KIT

Connect the rectifier in accordance with Wiring Diagram 3495WD furnished with the kit.

* * *

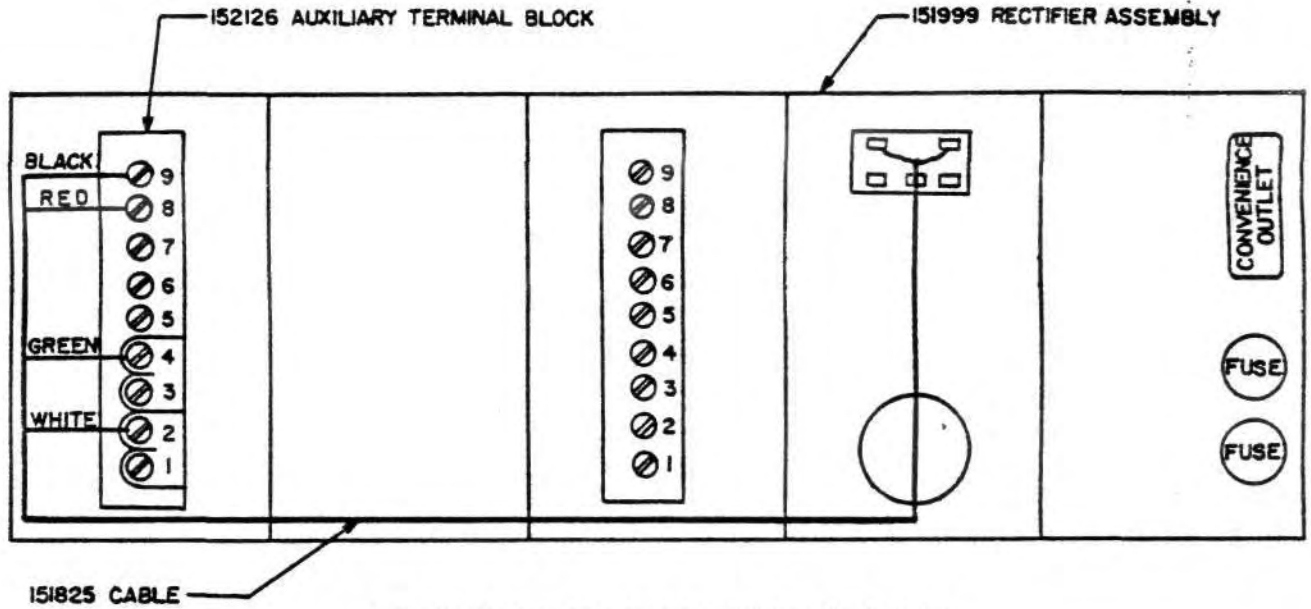

BOTTOM VIEW OF ELECTRICAL SERVICE UNIT (LESU1)

FIGURE 1

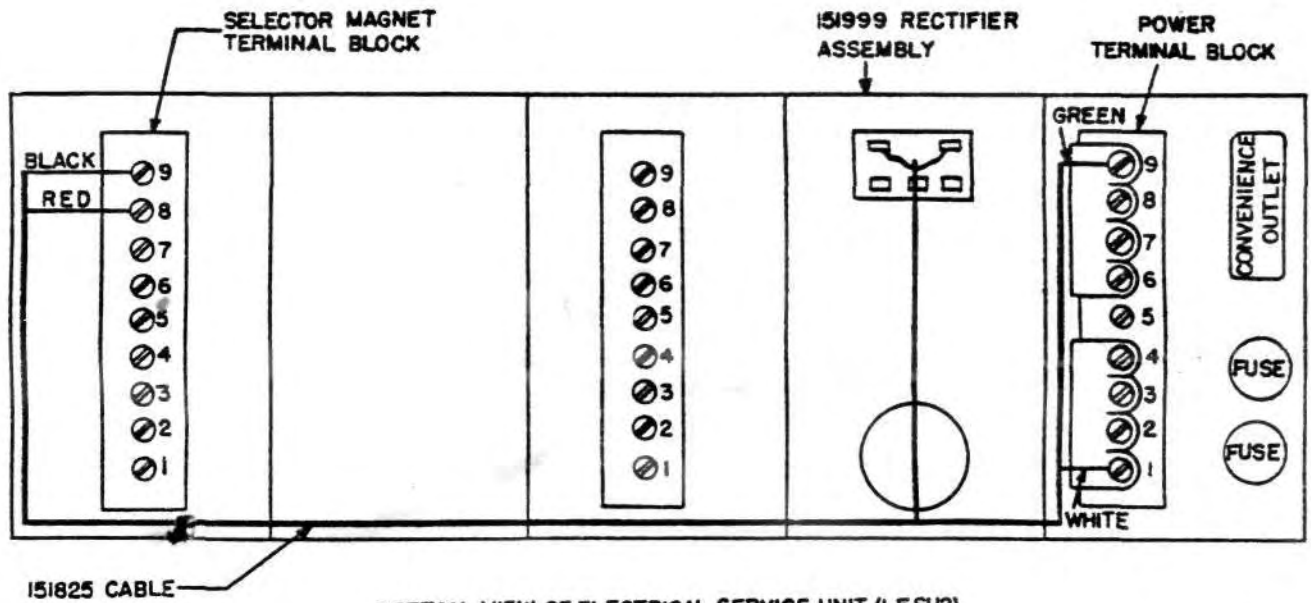

BOTTOM VIEW OF ELECTRICAL SERVICE UNIT (LESU2)

FIGURE 2

5707S

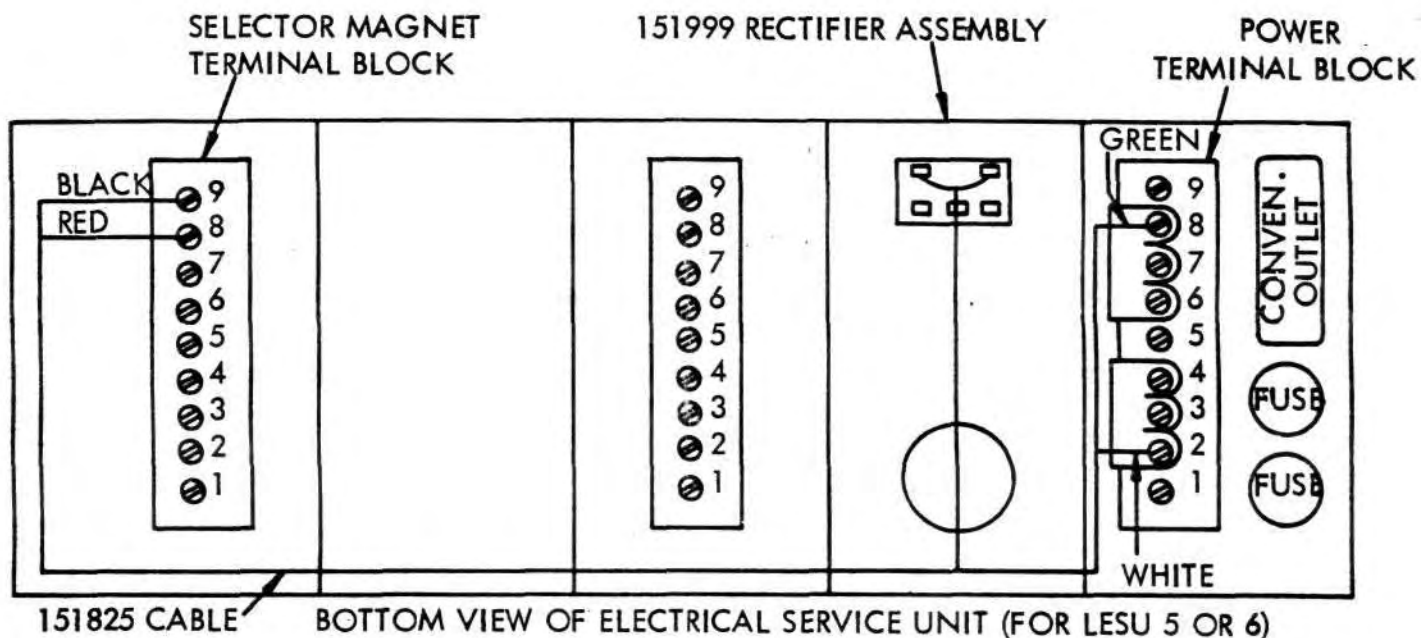
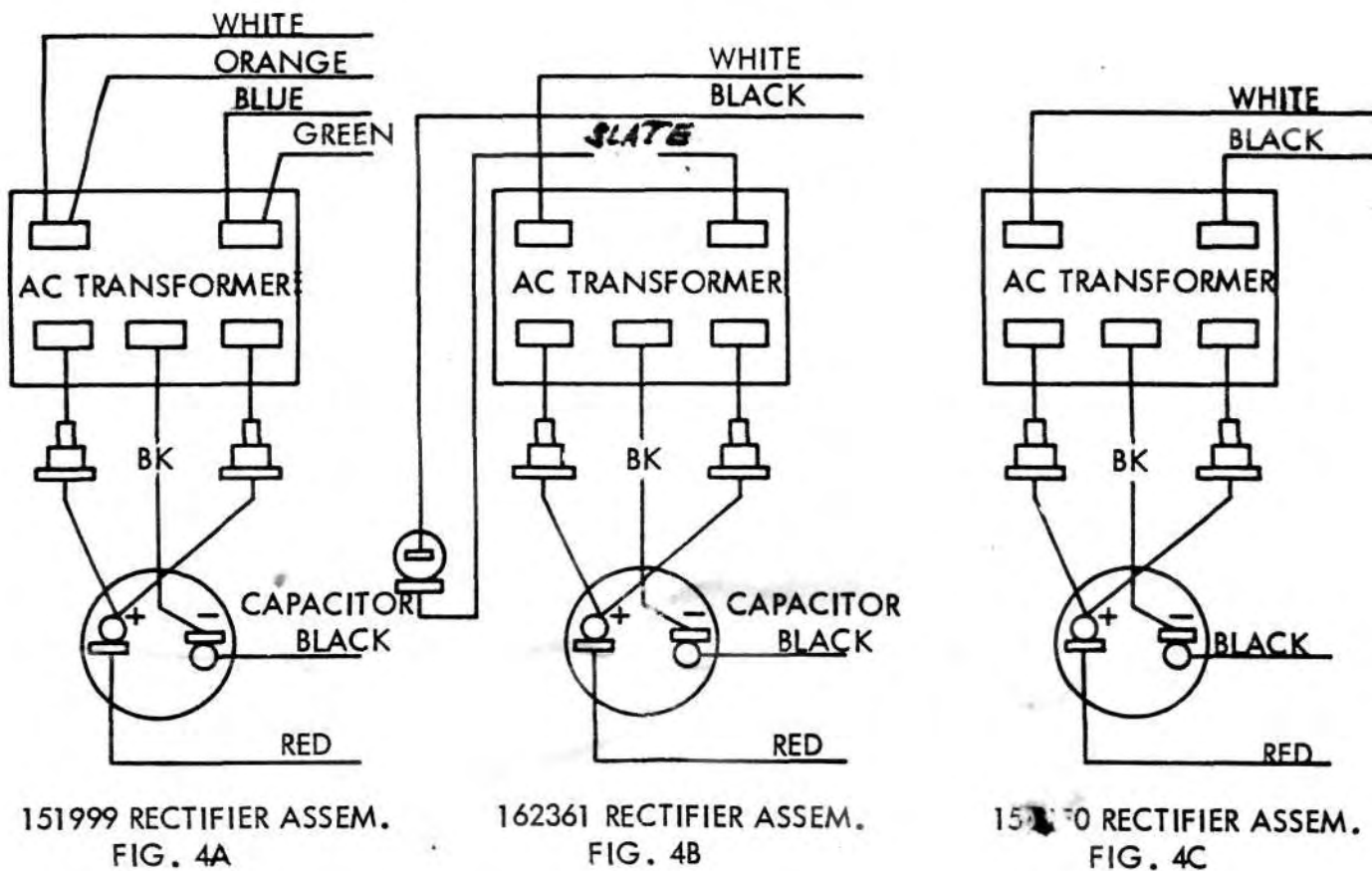
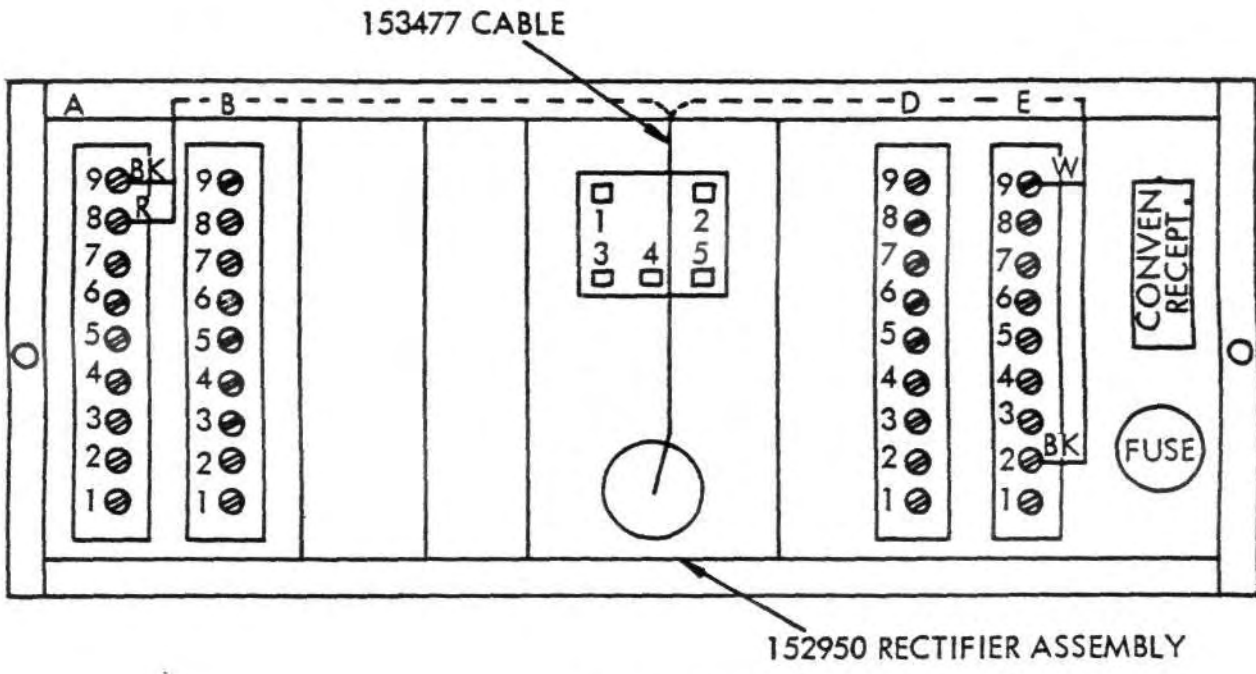
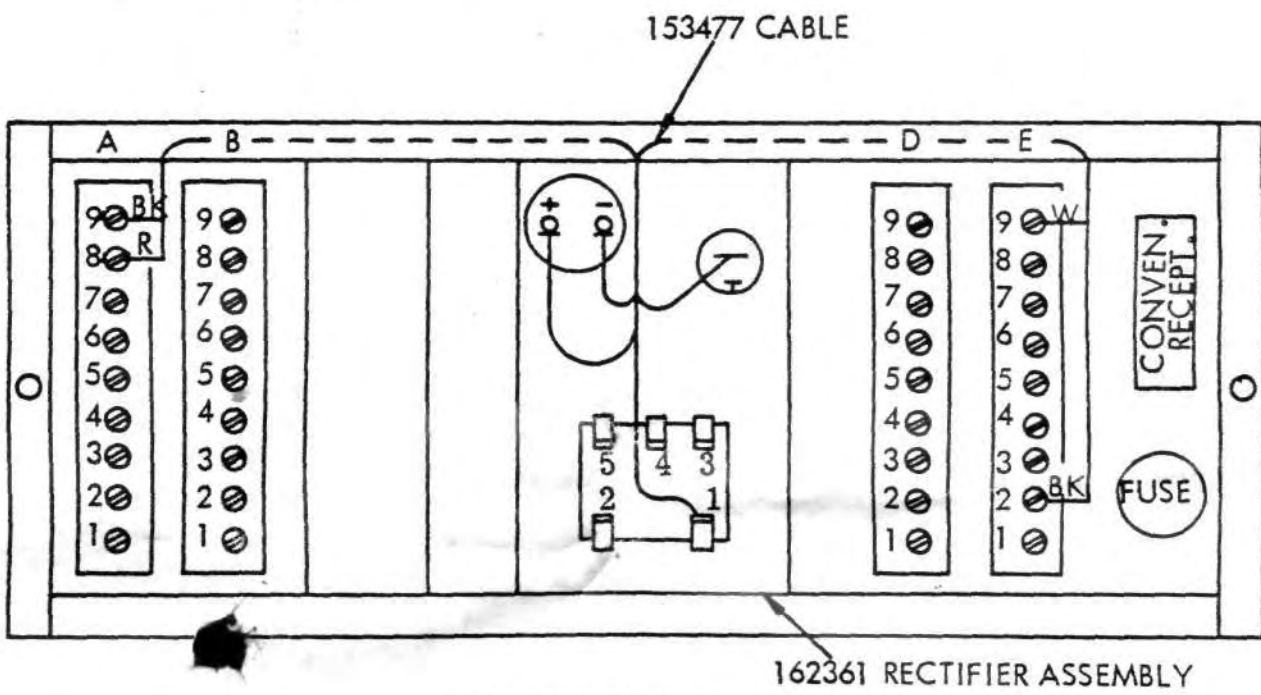

FIGURE 3





BOTTOM VIEW
FIGURE 5



BOTTOM VIEW
FIGURE 6